

► **Code Number**

3370003

► **Description**

Exposed, Solar Powered, Sensor Activated Sloan SOLIS® Model Water Closet Flushometer for floor mounted or wall hung top spud bowls.

► **Flush Cycle**

3.5 gpf/13.2 lpf

► **Specifications**

Quiet, Exposed, Diaphragm Type, Closet Flushometer for either left or right hand supply with the following features:

- Exposed parts Polished Brass
- Handle Packing, Main Seat, Stop Seat and Vacuum Breaker Molded from PERMEX® Rubber Compound for Chloramine resistance
- Initial Set-up Range Indicator Light (first 10 minutes)
- User friendly three (3) second Flush Delay
- "Low Battery" Flashing LED
- Sweat solder adapter with cover tube and cast wall flange with set screw
- Solar Powered. The sensor assembly is powered by a solar cell that will harvest power from artificial indoor light, either incandescent or fluorescent light, and use it as the energy source. The solar cell can provide approximately 100% power with 650 Illuminance (lux).
- Four (4) Size AA Battery Back-up Power Source
- Infrared Sensor with Multiple-focused, Lobular Sensing Fields for high and low target detection
- Latching Solenoid Operator
- Infrared Sensor Range Adjustment Screw
- Fixed Metering Bypass and No External Volume Adjustment to Ensure Water Conservation
- PERMEX® Synthetic Rubber Flex Tube Diaphragm with twin linear filtered bypass and vortex cleansing action
- Flex Tube Diaphragm designed for improved life and reduced maintenance
- Engineered Metal Cover with replaceable Lens Window
- ADA Compliant Sloan Solis® Solar Powered Infrared Sensor for automatic "No Hands" operation
- Courtesy Flush® Override Button
- Flush accuracy controlled by CID® technology
- Spud Coupling and Flange for 1 1/2" Top Spud

Valve Body, Cover, Tailpiece and Control Stop shall be in conformance with ASTM Alloy Classification for Red Brass. Valve shall be in compliance to the applicable sections of ASSE 1037 and ANSI/ASME 112.19.2.

- 1" I.P.S. Screwdriver Bak-Chek® Angle Stop with Free Spinning Vandal Resistant Stop Cap

► **Fixtures**

Consult factory for matching Sloan brand fixture options.

► **ELECTRICAL SPECIFICATIONS**

Control Circuit

Solid State



► **Automatic Operation**

Sloan SOLIS® Solar powered Flushometers can also be activated via multi-lobular infrared sensor. Sloan's SOLIS® Solar powered Flushometer is a breakthrough in design and function that transforms light into power. The SOLIS® Series of Flushometers provide the ultimate in conservation and performance.

► **Manual Operation**

Sloan SOLIS® Solar powered Flushometers incorporate a intuitive button design for easy manual activation. Straightforward graphics alert user to proper activation. To further educate the user, two (2) instructional wall plates are included with each Sloan Solis® Flushometer.

► **Functional & Hygienic**

Touchless, sensor operation eliminates the need for user contact to help control the spread of infectious diseases. The SOLIS® solar-powered flushometers is provided with an override button to allow a Courtesy Flush® for individual user comfort.

► **Compliance & Certifications**



This space for Architect/Engineer Approval

- 6 VDC Input
- 8 Second Arming Delay
- 3 Second Flush Delay

Sensor Type

Active Infrared

Sensor Range

Nominal 22" - 42" (559 mm - 1067 mm) Self-adaptive Window: ± 10" (254 mm)

Battery Back Up Type

(4) AA Alkaline

Battery Life

6 Years @ 4,000 flushes/month

Indicator Lights

Range Adjustment

Operating Pressure

15 - 100 psi (104 - 689 kPa)

Sentinel Flush

Automatic flush once every 72 hours after the last flush. Product shipped from factory with feature turned off. Consult factory to activate.

▶ ROUGH-IN

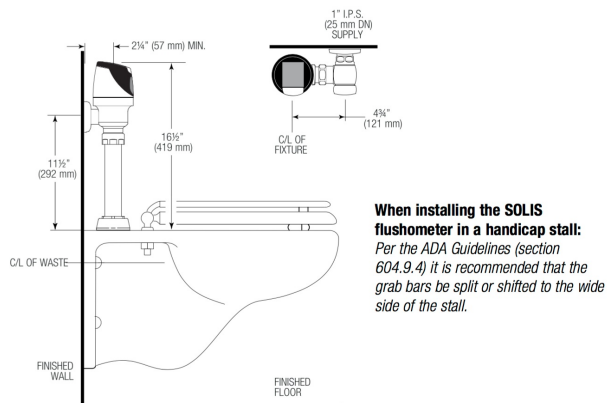
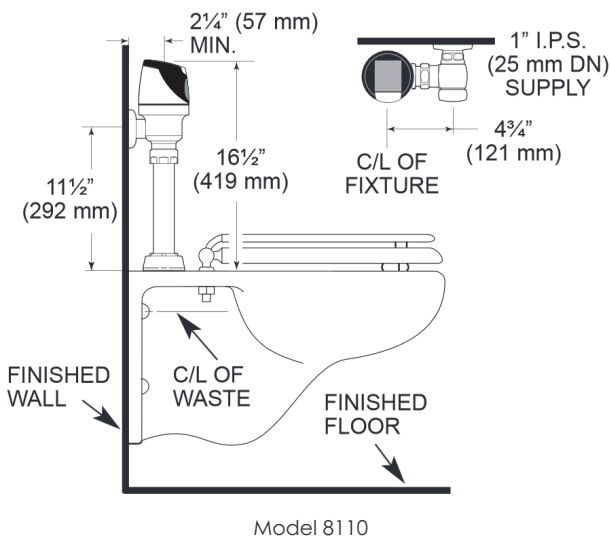

▶ OPERATION

1. A continuous, invisible light beam is emitted from the SOLIS® sensor.

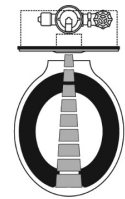

2. As the user enters the beam's effective range (22" to 42") the beam is reflected into the SOLIS® Scanner Window and transformed into a low voltage electrical circuit. Once activated, the Output Circuit continues in a "hold" mode for as long as the user remains within the effective range of the Sensor.

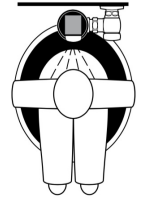

3. When the user steps away from the SOLIS® Sensor, the Sensor initiates an electrical signal that operates the Solenoid. This initiates the flushing cycle to flush the fixture. The Circuit then automatically resets and is ready for the next user.

